

SOUTH ROAD, A P.U.D. PLAT II

A REPLAT OF LOT 5, BLOCK 35, "PALM BEACH FARMS CO. PLAT NO. 3" (PB. 2, PGS. 45-54 P.B.C.R.) IN SECTION 36, TOWNSHIP 44 SOUTH, RANGE 41 EAST AND A REPLAT OF TRACTS B-1, L-1, LOTS 32, 33, 34, 56, 57, 58, 59 AND A PORTION OF TRACT A, SOUTH ROAD, A P.U.D. (PB. 95, PGS. 76-79 P.B.C.R.) PALM BEACH COUNTY, FLORIDA

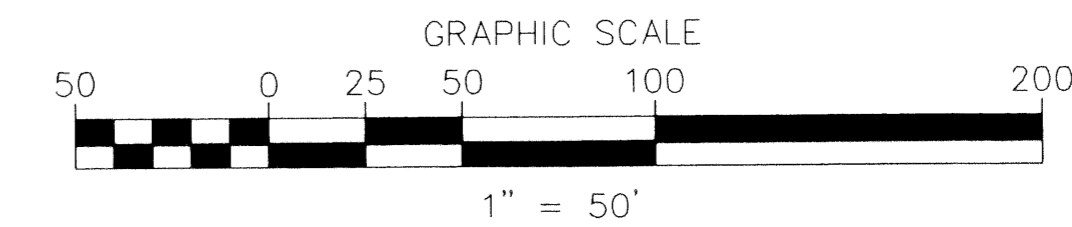

115

STATE OF FLORIDA
COUNTY OF PALM BEACH

THIS PLAT WAS FILED FOR RECORD AT _____ THIS _____ DAY OF _____ 200____ AND DULY RECORDED IN PLAT BOOK _____ ON PAGES _____ THROUGH _____

DOROTHY H. WILKEN, CLERK
BY: _____DC

SHEET 2 OF 5

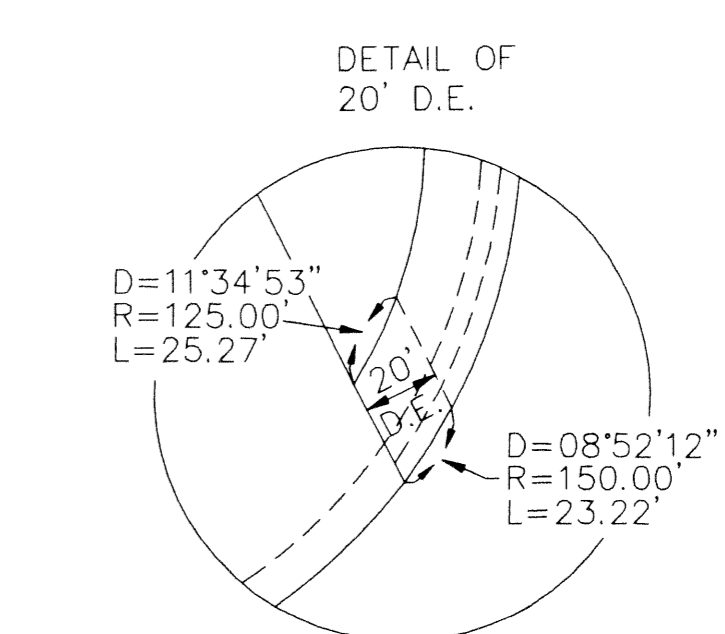
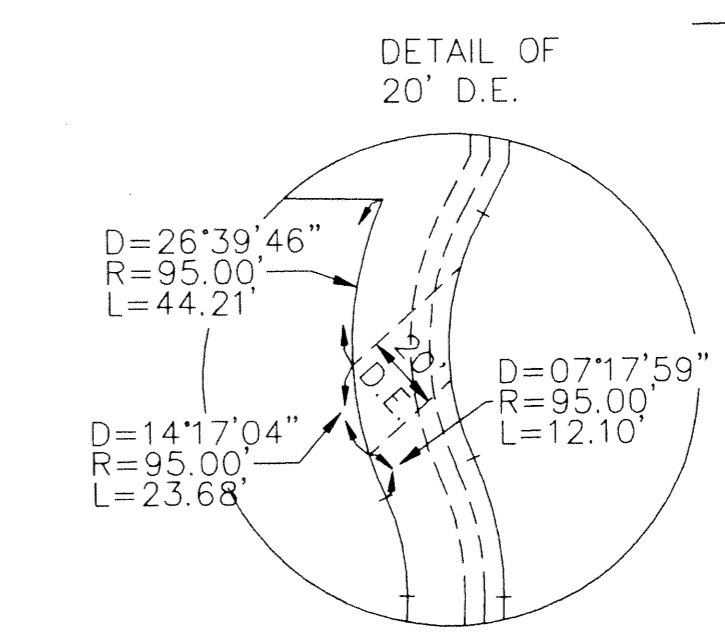
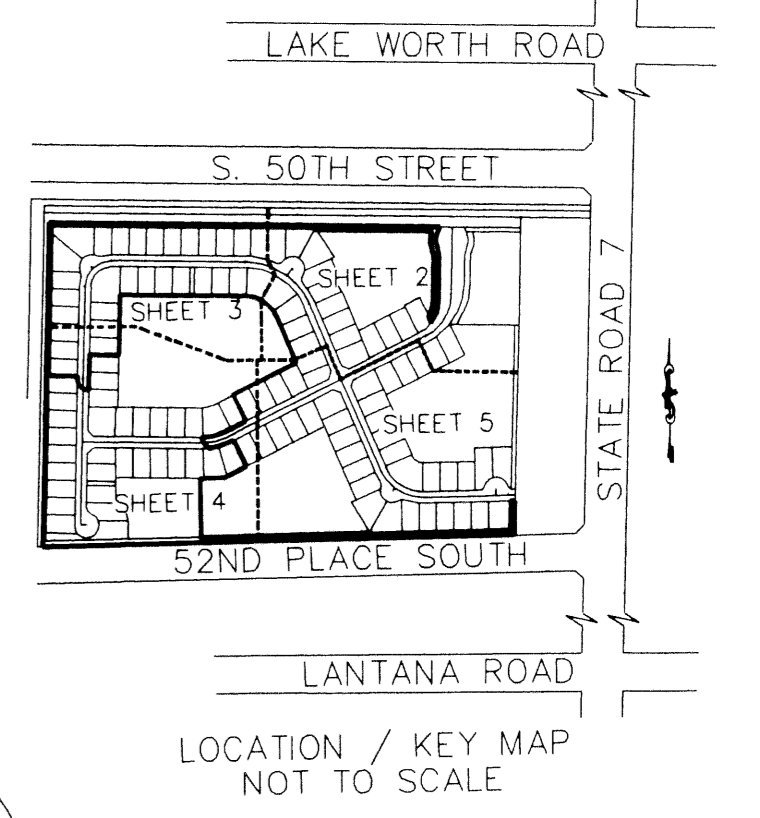
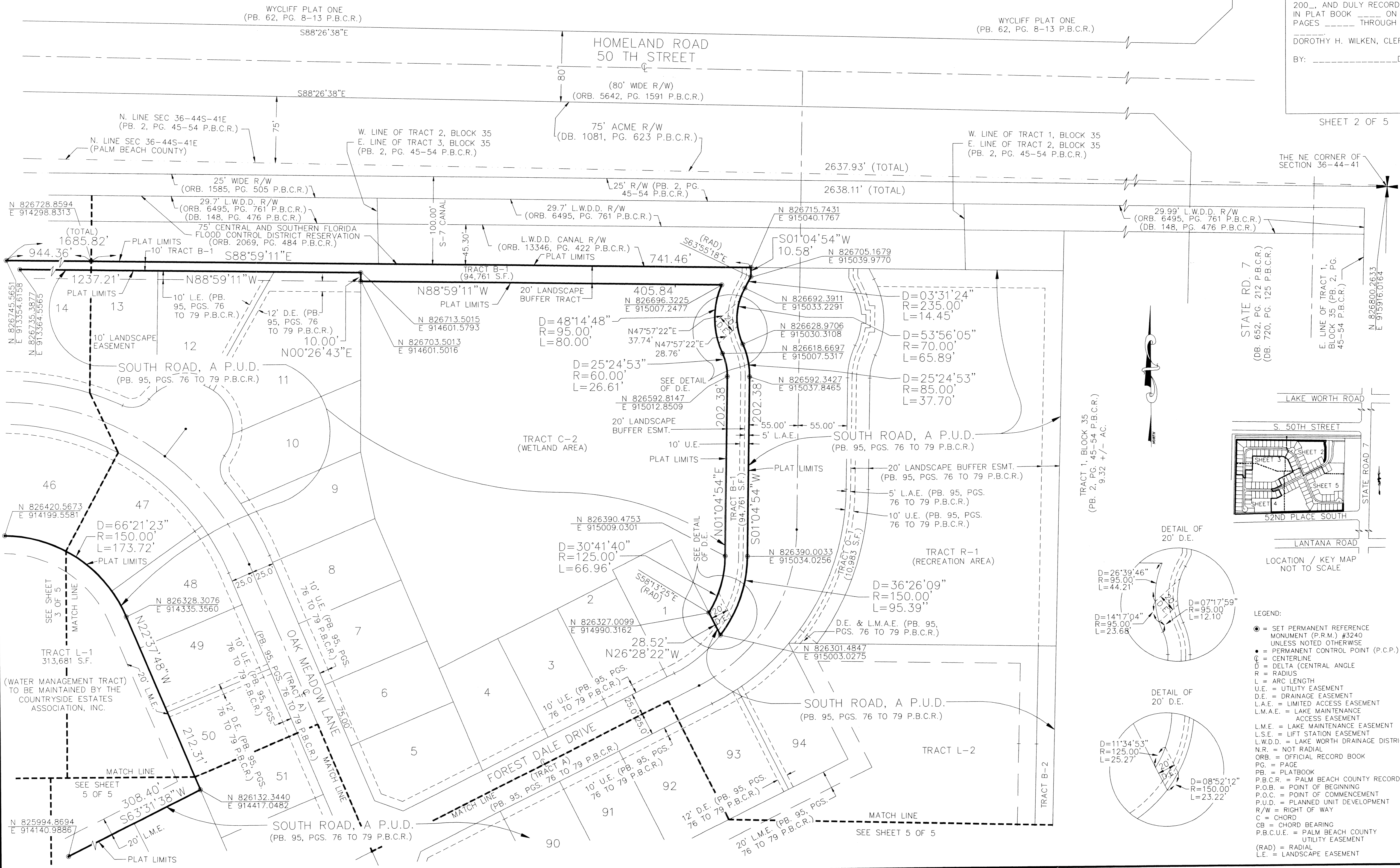

- LEGEND:
- = SET PERMANENT REFERENCE MONUMENT (P.R.M.) #3240 UNLESS NOTED OTHERWISE
 - = PERMANENT CONTROL POINT (P.C.P.)
 - C = CENTERLINE
 - D = DELTA (CENTRAL ANGLE)
 - R = RADIUS
 - L = ARC LENGTH
 - U.E. = UTILITY EASEMENT
 - D.E. = DRAINAGE EASEMENT
 - L.A.E. = LIMITED ACCESS EASEMENT
 - L.M.A.E. = LAKE MAINTENANCE ACCESS EASEMENT
 - L.M.E. = LAKE MAINTENANCE EASEMENT
 - L.S.E. = LIFT STATION EASEMENT
 - L.W.D.D. = LAKE WORTH DRAINAGE DISTRICT
 - N.R. = NOT RADIAL
 - ORB. = OFFICIAL RECORD BOOK
 - PG. = PAGE
 - PB. = PLATBOOK
 - P.B.C.R. = PALM BEACH COUNTY RECORDS
 - P.O.B. = POINT OF BEGINNING
 - P.O.C. = POINT OF COMMENCEMENT
 - P.U.D. = PLANNED UNIT DEVELOPMENT
 - R/W = RIGHT OF WAY
 - C = CHORD
 - CB = CHORD BEARING
 - P.B.C.U.E. = PALM BEACH COUNTY UTILITY EASEMENT
 - (RAD) = RADIAL
 - L.E. = LANDSCAPE EASEMENT

SUBDIVISION South Road PUD PLAT 2
 BOOK 102
 FLOOD ZONE B
 ZONING PUD
 QUAD # 03
 SS
 TAZ 102
 FUD NAME South Road

(WATER MANAGEMENT TRACT) TO BE MAINTAINED BY THE COUNTRYSIDE ESTATES ASSOCIATION, INC.

SEE SHEET 5 OF 5